

Exacore Infrastructure

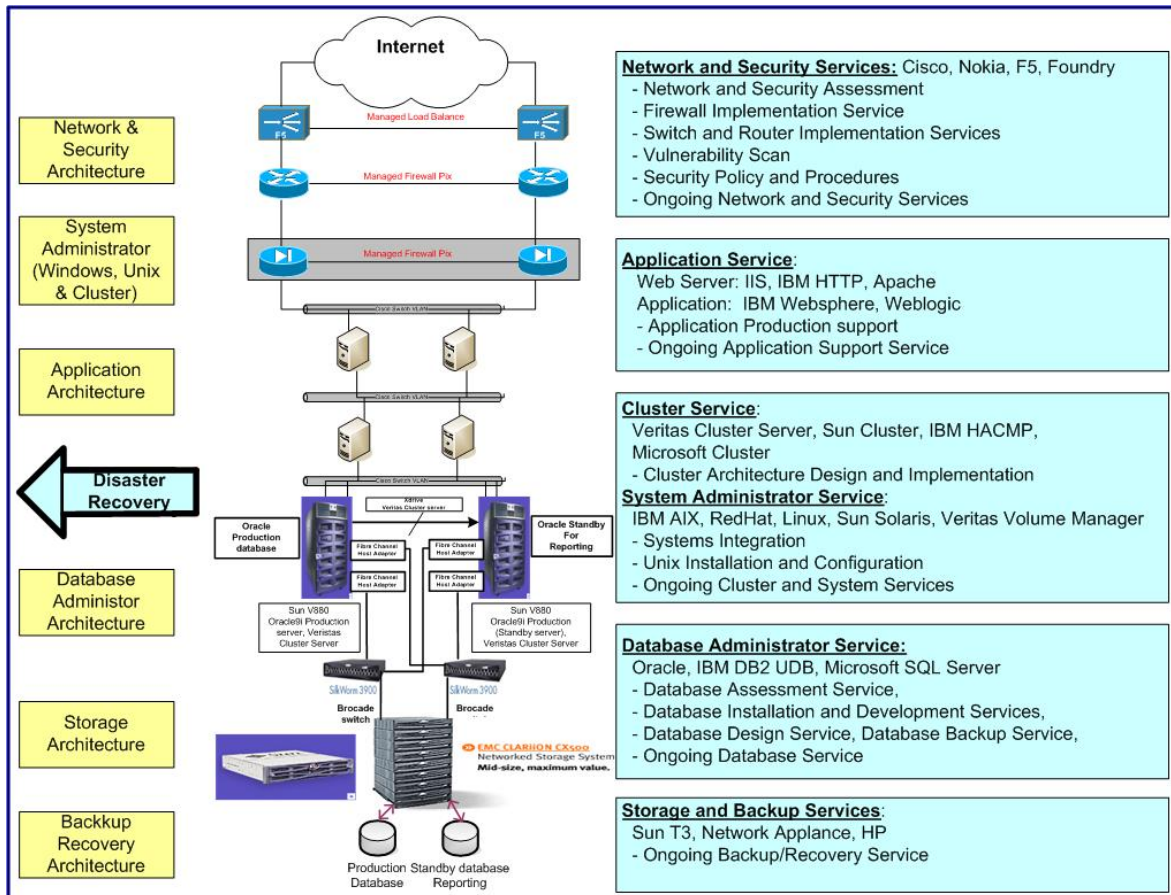

Exacore's customer infrastructure needs are well defined:

1. *Access to data* which is addressed in the XML repository data applications; access to services which is done with the web services business applications; and access to networks primarily in the WiMAX area including internetworking and network applications.

2. *Integration* with commerce and the worldwide web. Business integration with operations affects both the management and technology of the customer. Web integration includes Intranet (portal and web applications) and Internet (public communication and electronic distribution).

For additional information contact "chris.webb@exacore.net"